

**Produce Large Volumes Of Fresh Concrete Rapidly With Our Off-Road Mobile Batching Plant.**

**DISCHARGE:** With the 360° slewing drum, the operator discharges the concrete on the four sides of the machine at a height of 6'5", in just 10-15 minutes. Mixing drum volume is 1281 gallons.

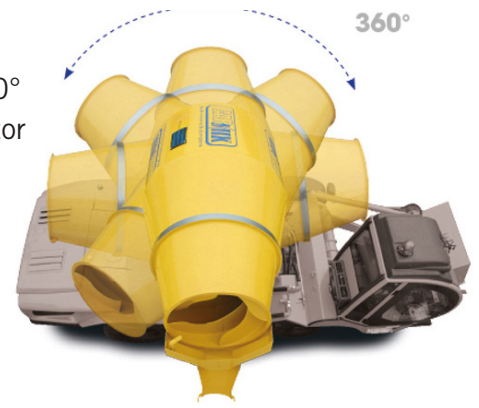

**CAPACITY:** 100 YD3 / PER 8 HOUR SHIFT

**Obtain A Perfect Mix, Suitable For Any Job Or Situation.**



**CONCRETE MATE:**

Ultimate "4 sensor" electronic scale, easy to use and extra accurate for any kind of mix.

**PROMIX:** In-drum probe, easy allows to analyze your concrete: slump, volume, temperature and ready-mix indicator.

**4 x 4 x 4**

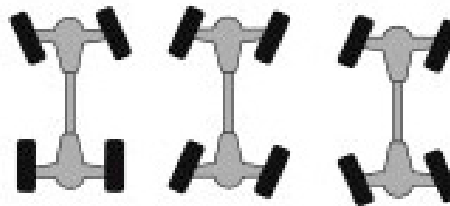

**TIRES:** Off road industrial type 16/70-20 PR 14.

**STEERING:** Hydrostatic. 3 ways steering. 4 wheel drive and steering.

**RENT THIS ALL-WHEEL DRIVE CONCRETE MIXER WITH SELF-LOADING FUNCTION:**

We can train your drivers or use ours.

**LOADING SHOVEL SELF ARTICULATED:**

Effective capacity per load 158 gallons, complete with hydraulic opening gate.

**FAST, ACCURATE, FULLY AUTOMATED:**

A fully automated system for ease of use, also suitable for inexperienced operators.

**SPEED:** Working speed from 0 to 5.6 mph, road transfer from 0 to 15.5 mph.

07/03/2019 14:33		07/03/2019 14:40	
Start Date/Time	07/03/2019 14:33	Start Date/Time	07/03/2019 14:40
End Date/Time	07/03/2019 14:33	End Date/Time	07/03/2019 14:40
RECEIPT			
MIXTURE 21			
PRODUCT	WEIGHT	PRODUCT	WEIGHT
WATER	510	WATER	420
CEMENT	42.5	CEMENT	42.5
GRAVEL 1	2,400	GRAVEL 1	2,410
SAND 1	3,000	SAND 1	3,100
TOTAL LOADED	7070	TOTAL LOADED	7070
TARGET TOTAL	7050	TARGET TOTAL	7050
TOTAL ERROR	49.0-3.0	TOTAL ERROR	49.0-3.0
CUSTOMER			
GREENPLANT, INC.			
LONDON ROAD			
WHEATLEY, OXFORD			
UK			
DNK83 12H			
MACHINE CODE			
CAREXK P30188			
OPERATOR ID			
STEVE			
TICKET NUMBER			
000001		000002	
SIGNATURE			

RECIPE WITHOUT HUMIDITY

RECIPE WITH 3% HUMIDITY

TO LEARN MORE, VISIT: [www.ConcreteBatchSolutions.com](http://www.ConcreteBatchSolutions.com)

(561) 969-7147 • CONCRETE BATCH SOLUTIONS, LLC. • 3705 Bellevue Avenue • Lake Worth, Florida 33461

**CONCRETE  
BATCH  
SOLUTIONS LLC.**



## Create Concrete On The Toughest Job Sites!

**RENT THIS SELF LOADING MIXER UNIT**  
for your next large or medium-sized project, high-rise building or structure, as well as for the manufacture of ready-mix concrete.

**THIS MOBILE CONCRETE PLANT**  
loads aggregates and kneads concrete of the desired specs according to a given mix design.

**HIGH PERFORMANCE**  
stability and manoeuvrability into hard-to-reach places.

### SPECS: Off Road Mobile Batching Plant

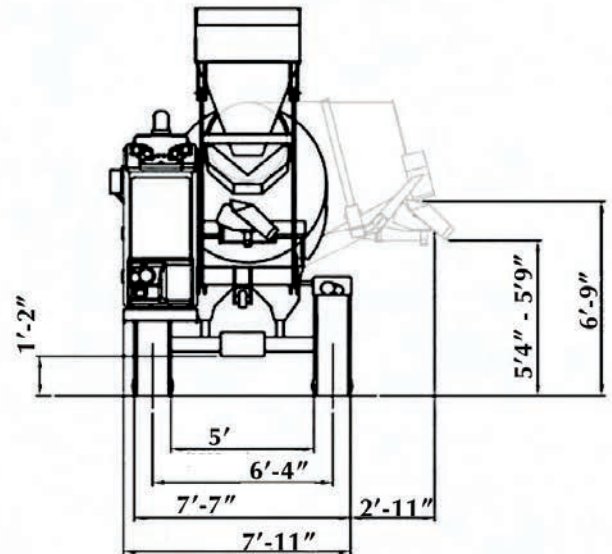
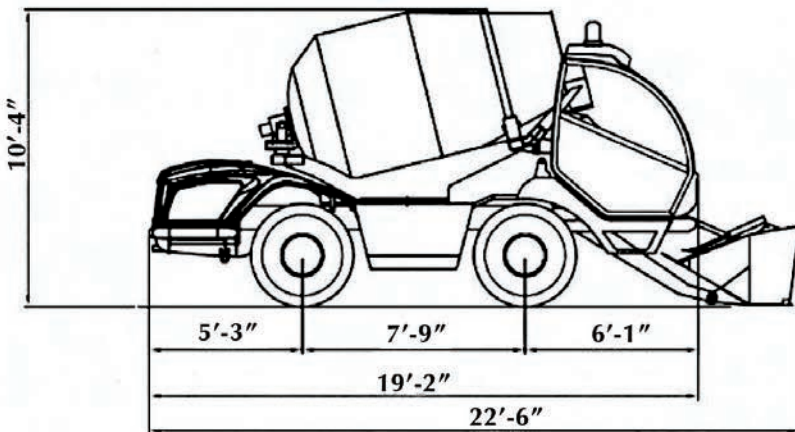

TO LEARN MORE, VISIT: [www.ConcreteBatchSolutions.com](http://www.ConcreteBatchSolutions.com)

(561) 969-7147 • CONCRETE BATCH SOLUTIONS, LLC. • 3705 Bellevue Avenue • Lake Worth, Florida 33461